

Figure 102 — Cylindricity indication

The tolerance zone defined by the specification in [Figure 102](#), is limited by two coaxial cylinders with a difference in radii of  $t$ , see [Figure 103](#).

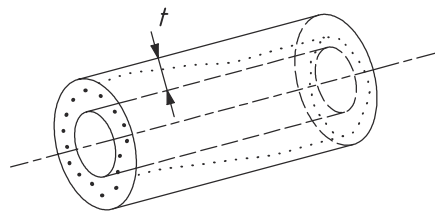
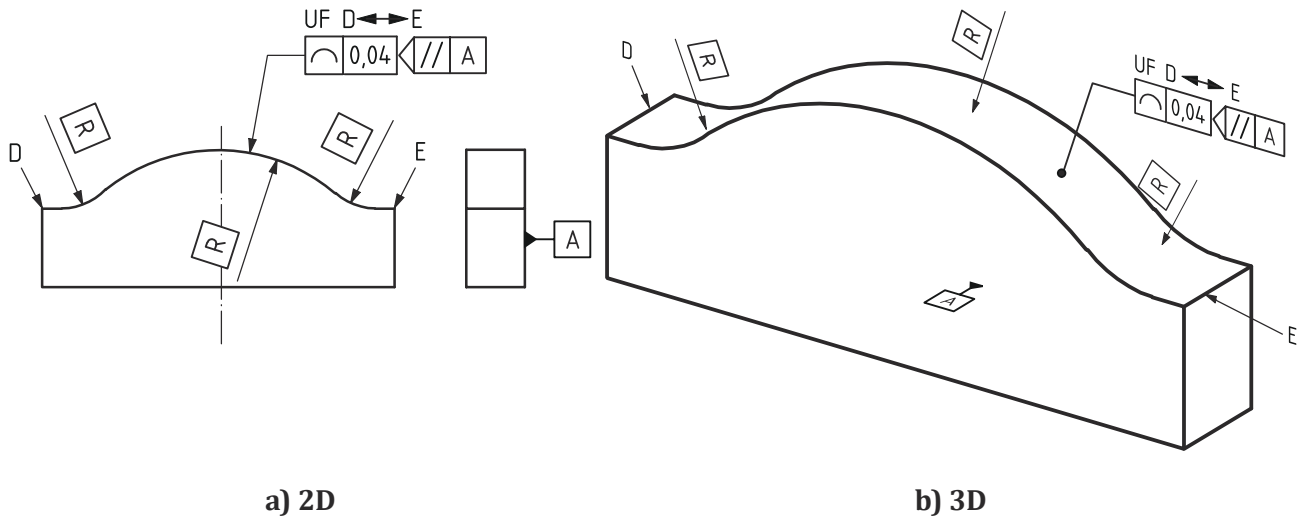

Figure 103 — Definition of the cylindricity tolerance zone

### 17.6 Line profile specification not related to a datum

The tolerated feature can be an integral feature or a derived feature. The nature of the nominal tolerated feature is explicitly given as a linear feature or a set of linear features. The shape of the nominal tolerated feature, except in the case of a straight line, shall be explicitly given by complete indications on the drawing or by queries of the CAD model, see ISO 16792.

In [Figure 104](#), in each section, parallel to datum plane A, as specified by the intersection plane indicator, the extracted profile line shall be contained between two equidistant lines enveloping circles of diameter 0,04, the centres of which are situated on a line having the theoretically exact geometrical form. The UF specification element is used to indicate that the three circular sections in the compound feature shall be combined into one united feature. For deprecated 2D practice, see [A.2.1](#). For former practice regarding the extent of the tolerated feature, see [A.3.5](#).



NOTE Some of the TEDs necessary for an unambiguous definition of the nominal geometry are not shown.

Figure 104 — Line profile indication

The tolerance zone defined by the specification in Figure 104 is limited by two lines enveloping circles of diameter  $t$ , the centres of which are situated on a line having the theoretically exact geometrical form, see Figure 105.

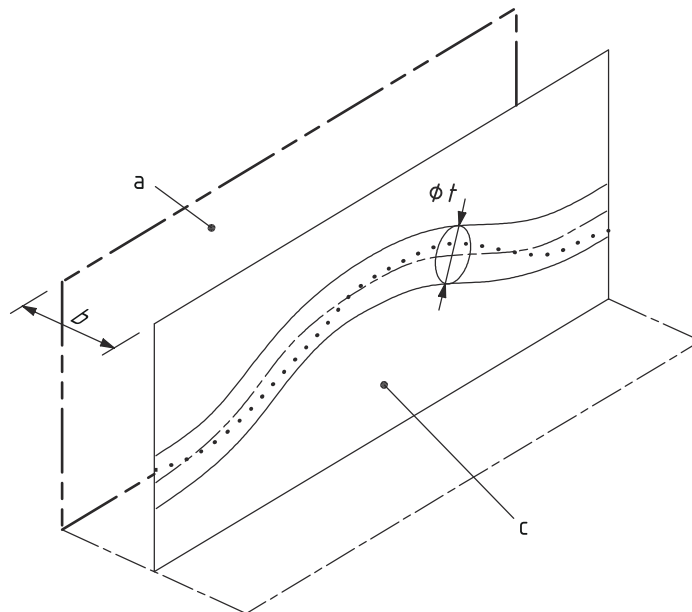

- a Datum plane A.
- b Any distance.
- c Plane parallel to datum plane A.

Figure 105 — Definition of the line profile tolerance zone

### 17.7 Line profile specification related to a datum system

The tolerated feature can be an integral feature or a derived feature. The nature of the nominal tolerated feature is explicitly given as a linear feature or a set of linear features. The shape of the

nominal toleranced feature, except in the case of a straight line, shall be explicitly given by complete indications on the drawing or by queries of the CAD model, see ISO 16792.

In [Figure 106](#), in each section, parallel to datum plane A, as specified by the intersection plane indicator, the extracted profile line shall be contained between two equidistant lines enveloping circles of diameter 0,04, the centres of which are situated on a line having the theoretically exact geometrical form with respect to datum plane A and datum plane B. For deprecated 2D practice, see [A.2.1](#).

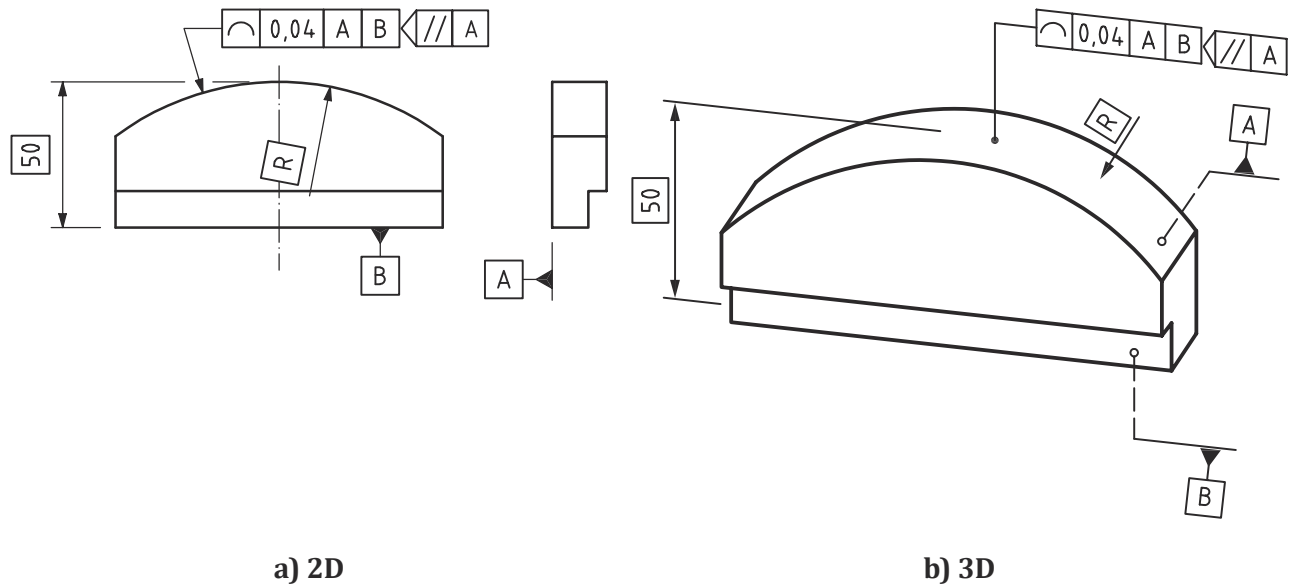

NOTE Some of the TEDs necessary for an unambiguous definition of the nominal geometry are not shown.

**Figure 106 — Line profile indication**

The tolerance zone defined by the specification in [Figure 106](#) is limited by two lines enveloping circles of diameter  $t$ , the centres of which are situated on a line having the theoretically exact geometrical form with respect to datum plane A and datum plane B, see [Figure 107](#).

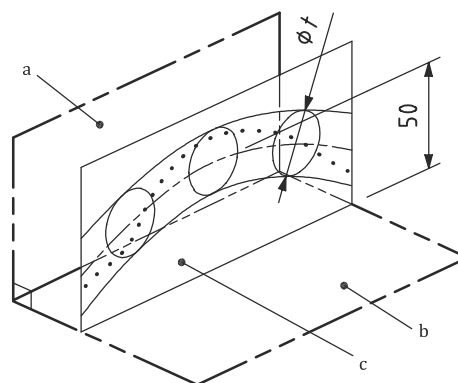

- a Datum A.
- b Datum B.
- c Plane parallel to datum A.

**Figure 107 — Definition of the line profile tolerance zone**

### 17.8 Surface profile specification not related to a datum

The tolerated feature can be an integral feature or a derived feature. The nature of the nominal tolerated feature is explicitly given as an areal feature. The shape of the nominal tolerated feature, except in the case of a flat surface, shall be explicitly given by complete indications on the drawing or by queries of the CAD model, see ISO 16792.

In [Figure 108](#), the extracted surface shall be contained between two equidistant surfaces enveloping spheres of diameter 0,02, the centres of which are situated on a surface having the theoretically exact geometrical form.

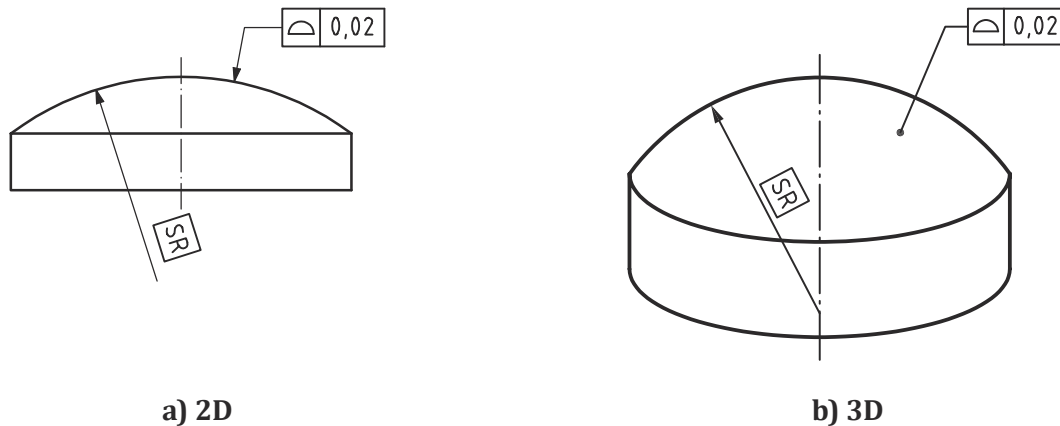

Figure 108 — Surface profile indication

The tolerance zone defined by the specification in [Figure 108](#) is limited by two surfaces enveloping spheres of diameter  $t$ , the centres of which are situated on a surface having the theoretically exact geometrical form, see [Figure 109](#).

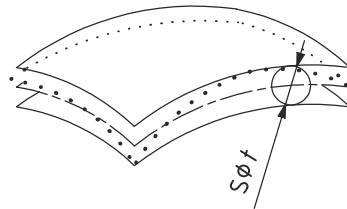

Figure 109 — Definition of the surface profile tolerance zone

### 17.9 Surface profile specification related to a datum

The tolerated feature can be an integral feature or a derived feature. The nature of the nominal tolerated feature is explicitly given as an areal feature. The shape of the nominal tolerated feature, except in the case of a flat surface, shall be explicitly given by complete indications on the drawing or by queries of the CAD model, see ISO 16792.

If the specification is an orientation specification, the  $\><$  specification element shall be placed in the second compartment of the tolerance indicator or after each datum indication in the tolerance indicator, or no datum that is able to lock a non-redundant translation of the tolerance zone shall be indicated. The angular dimensions that are locked between the nominal tolerated feature and the datums shall be defined by explicit or implicit TEDs or both, see ISO 5459.

If the specification is a location specification, at least one datum that locks a non-redundant translation of the tolerance zone shall be indicated in the tolerance indicator. The angular and linear dimensions

that are locked between the nominal toleranced feature and the datums shall be defined by explicit or implicit TEDs or both.

In [Figure 110](#), the extracted surface shall be contained between two equidistant surfaces enveloping spheres of diameter 0,1, the centres of which are situated on a surface having the theoretically exact geometrical form with respect to datum plane A.

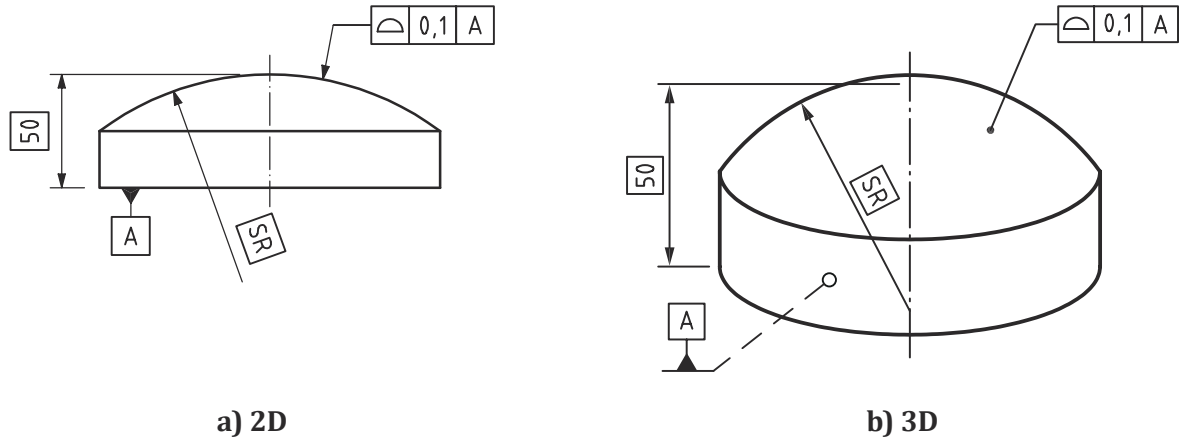

NOTE Some of the TEDs necessary for an unambiguous definition of the nominal geometry are not shown.

**Figure 110 — Surface profile indication**

The tolerance zone defined by the specification in [Figure 110](#) is limited by two surfaces enveloping spheres of diameter  $t$ , the centres of which are situated on a surface having the theoretically exact geometrical form with respect to datum plane A, see [Figure 111](#).

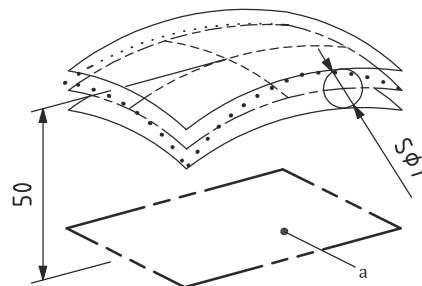

a Datum A.

**Figure 111 — Definition of the surface profile tolerance zone**

## 17.10 Parallelism specification

### 17.10.1 General

The toleranced feature can be an integral feature or a derived feature. The nature of the nominal toleranced feature is a linear feature, a set of linear features, or an areal feature. The shape of each nominal toleranced feature is explicitly given as a straight line or a flat surface. If the indicated feature is a nominally flat surface and the toleranced feature is a set of straight lines in that surface, an intersection plane indicator shall be indicated. The TED angles that are locked between the nominal toleranced feature and the datums shall be defined by implicit TEDs ( $0^\circ$ ).

**17.10.2 Parallelism specification of a median line related to a datum system**

In [Figure 112](#), the extracted median line shall be contained between two parallel planes 0,1 apart which are parallel to datum axis A. The planes limiting the tolerance zone are parallel to datum plane B as specified by the orientation plane indicator. Datum B is secondary to datum A. For former practice, see [A.3.6](#).

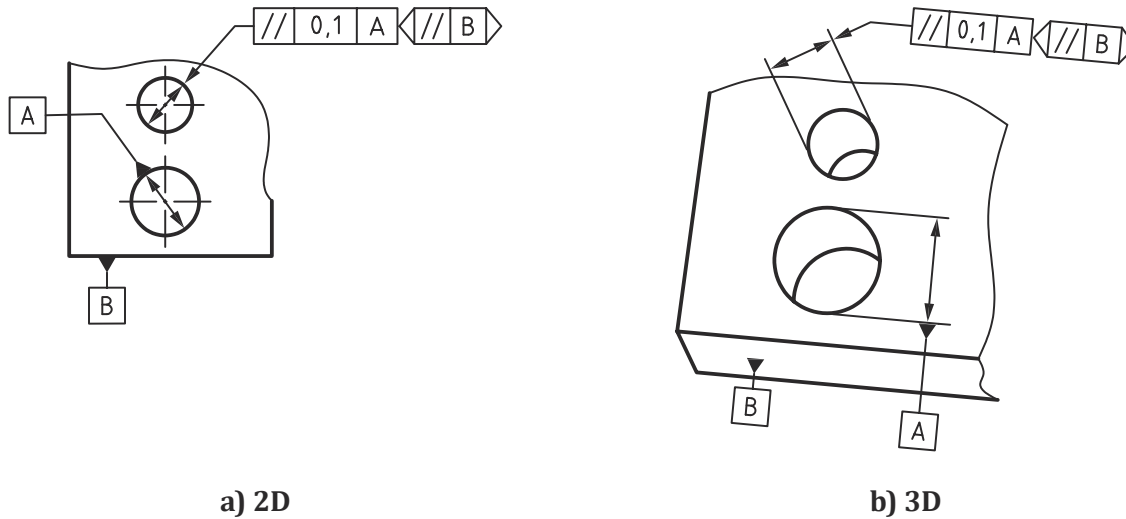

**Figure 112 — Parallelism indication**

The tolerance zone defined by the specification in [Figure 112](#) is limited by two parallel planes a distance *t* apart. The planes are parallel to the datums and in the direction specified, see [Figure 113](#).

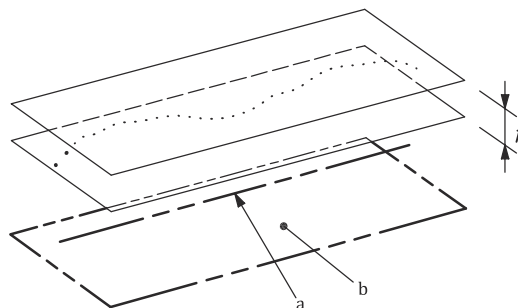

- a Datum A.
- b Datum B.

**Figure 113 — Definition of the parallelism tolerance zone**

In [Figure 114](#), the extracted median line shall be contained between two parallel planes 0,1 apart, which are parallel to datum axis A. The planes limiting the tolerance zone are perpendicular to datum plane B as specified by the orientation plane indicator. Datum B is secondary to datum A, see [14.4](#). For former practice, see [A.3.6](#).

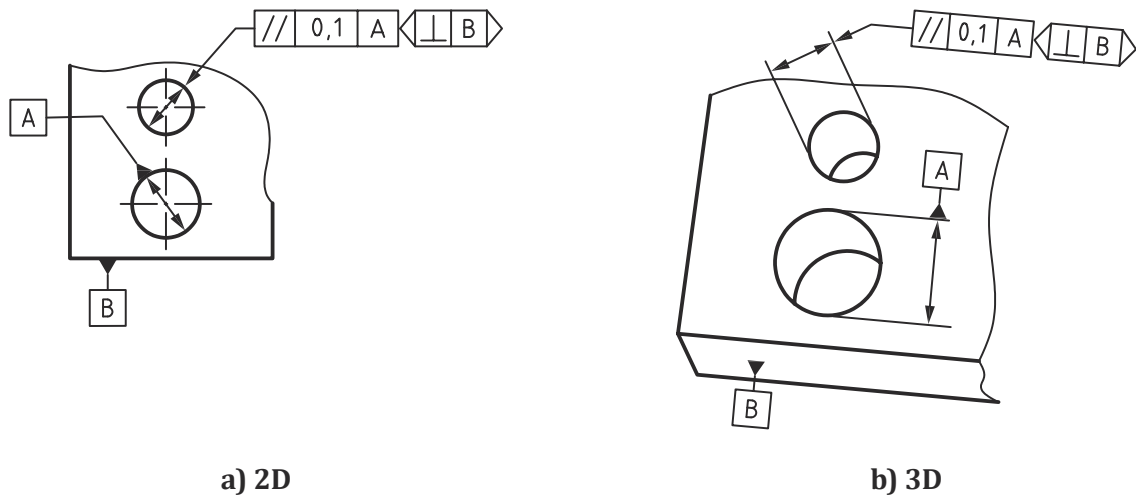

**Figure 114 — Parallelism indication**

The tolerance zone defined by the specification in [Figure 114](#) is limited by two parallel planes a distance  $t$  apart. The planes are parallel to datum A and perpendicular to datum B, see [Figure 115](#).

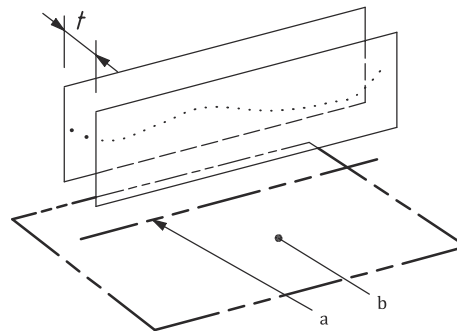

- a Datum A.
- b Datum B.

**Figure 115 — Definition of the parallelism tolerance zone**

In [Figure 116](#), the extracted median line shall be contained between two pairs of parallel planes, which are parallel to datum axis A, and positioned 0,1 and 0,2 apart respectively. The orientation of the planes limiting the tolerance zones is specified with respect to datum plane B by the orientation plane indicators. Datum B is secondary to datum A, see [14.4](#). For former practice, see [A.3.6](#).

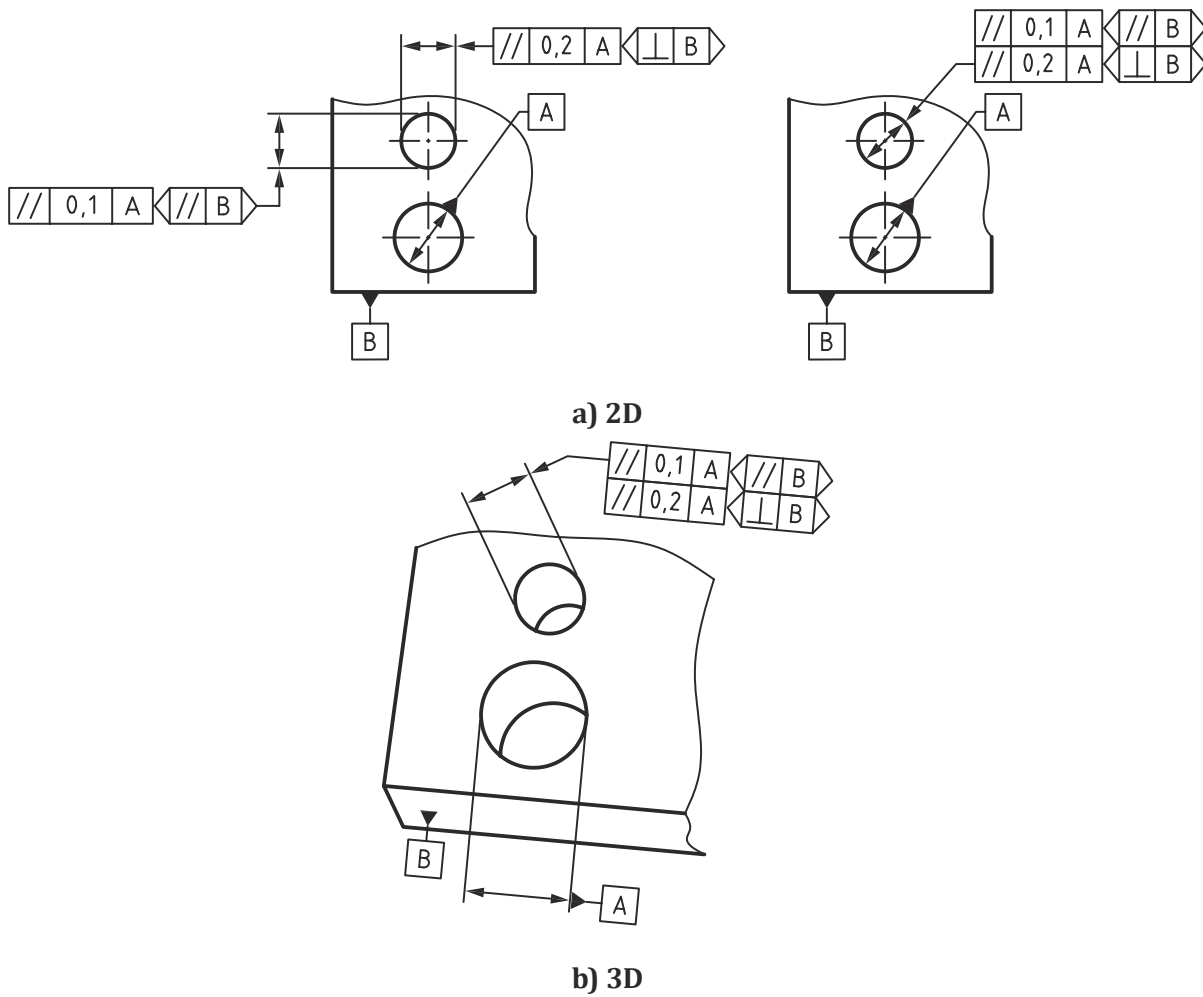
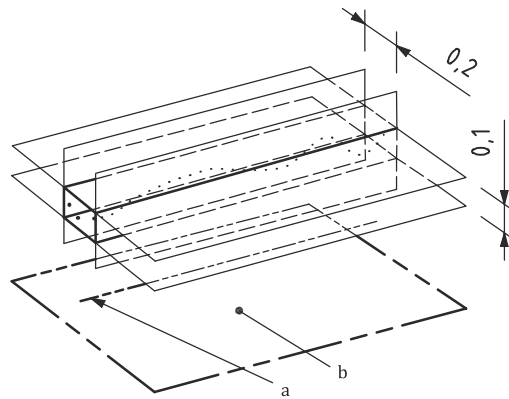

Figure 116 — Parallelism indication

Based on the specification in [Figure 116](#), the extracted median line shall be contained between two pairs of parallel planes, which are parallel to the datum axis A, and positioned 0,1 and 0,2 apart respectively, see [Figure 117](#). The orientations of the tolerance zones are specified with respect to datum plane B by the orientation plane indicators:

- the planes limiting the tolerance zone of 0,2 are perpendicular to the orientation plane B as specified by the orientation plane indicator;
- the planes limiting the tolerance zone of 0,1 are parallel to the orientation plane B as specified by the orientation plane indicator.



- a Datum A.
- b Datum B.

**Figure 117 — Definition of the parallelism tolerance zones**

### 17.10.3 Parallelism specification of a median line related to a datum straight line

In [Figure 118](#), the extracted median line shall be within a cylindrical zone of diameter 0,03, parallel to datum axis A.

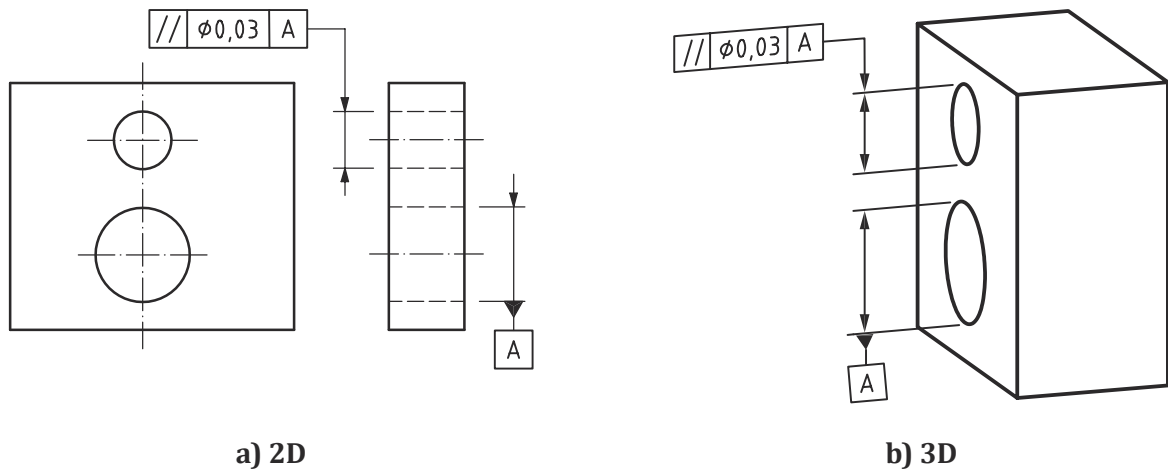

**Figure 118 — Parallelism indication**

The tolerance zone defined by the specification in [Figure 118](#) is limited by a cylinder of diameter  $t$ , parallel to the datum, because the tolerance value is preceded by the symbol  $\varnothing$ , see [Figure 119](#).

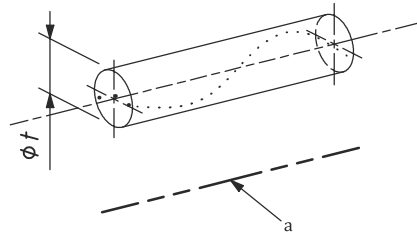

a Datum A.

Figure 119 — Definition of the parallelism tolerance zone

17.10.4 Parallelism specification of a median line related to a datum plane

In Figure 120, the extracted median line shall be contained between two parallel planes 0,01 apart, which are parallel to datum plane B.

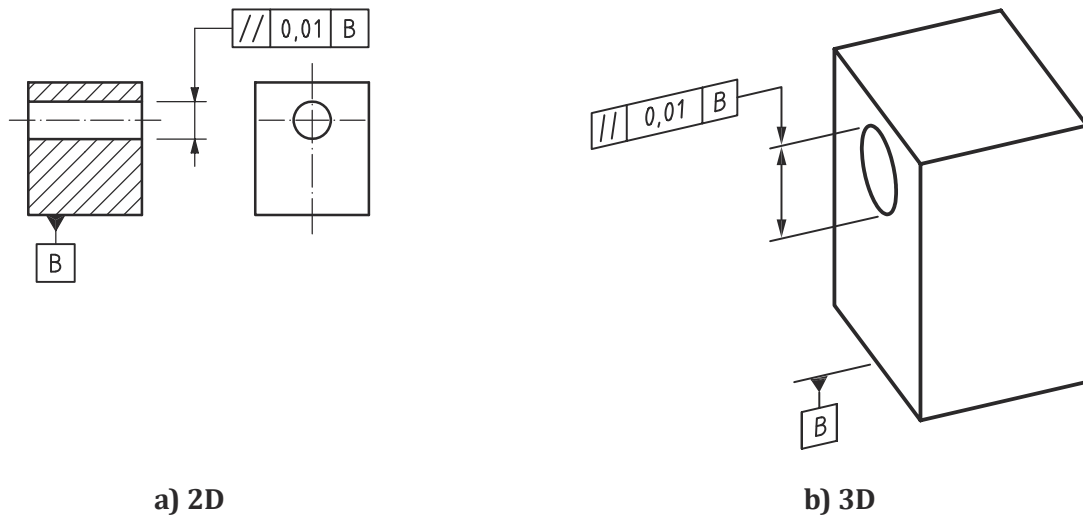
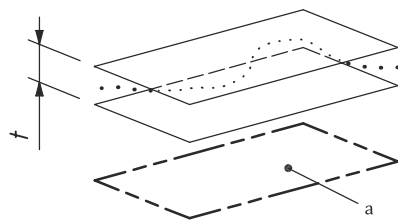

Figure 120 — Parallelism indication

The tolerance zone defined by the specification in Figure 120 is limited by two parallel planes a distance *t* apart and parallel to the datum, see Figure 121.



a Datum B.

Figure 121 — Definition of the parallelism tolerance zone